

ESR01P

Enclosed Relay 20 Amp DPDT with 120 Vac Coil

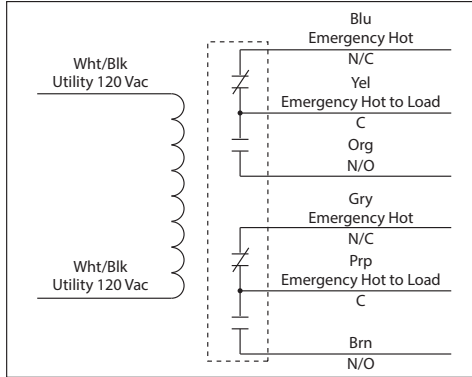

UL924 / 20 AMP BYPASS / SHUNT RELAY

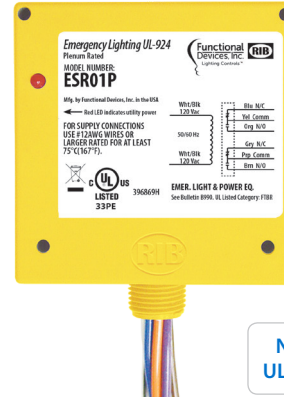

Not rated for use as a UL1008 Transfer Device

Specifications

Relays & Contact Type: One (1) DPDT Continuous Duty Coil
Expected Relay Life: 10 million cycles minimum mechanical
Operating Temperature: -30 to 140° F
Operate Time: 18ms
Relay Status: LED On = Normal power present
Dimensions: 4.00" x 4.00" x 1.80" with .50" NPT Nipple
Wires: 16", 600V Rated
Approvals: UL Listed, UL924, C-UL, CE, RoHS
Housing Rating: UL Accepted for Use in Plenum, NEMA 1
Gold Flash: Yes
Override (Test Switch): No

Contact Ratings:
 20 Amp Resistive @ 300 Vac
 20 Amp Resistive @ 28 Vdc
 20 Amp Ballast @ 277-480 Vac
Not rated for Electronic Ballast
 15 Amp Resistive @ 600 Vac
 770 VA Pilot Duty @ 120 Vac
 1158 VA Pilot Duty @ 240 Vac
 1109 VA Pilot Duty @ 277 Vac
 1640 VA Pilot Duty @ 480 Vac
 3 HP @ 480-600 Vac
 2 HP @ 240-277 Vac
 1 HP @ 120 Vac

Coil Current:
 105 mA @ 120 Vac

Coil Voltage Input:
 120 Vac ; 50-60 Hz
 Drop Out = 35 Vac
 Pull In = 85 Vac

Notes:
 • Not rated for use as a UL1008 Transfer Device.

Initial Wiring Verification

1. Turn OFF Normal Power and Transfer Power.
2. Wire relay according to wiring diagram.
3. Energize Transfer Power. Emergency Light should illuminate.
4. Energize Normal Power. Emergency Light will turn OFF.
5. Turn ON Emergency Zone Controller. Emergency Light should illuminate.

Field Inspection

1. Ensure Normal Power and Transfer Power are energized.
2. Red LED will be illuminated.
3. Turn OFF Normal Power. Red LED will turn OFF. Emergency Light will illuminate.

Shunt Relay Application

Our Bypass / Shunt Relays are UL924 Listed and suitable for shunting around wall switches in order to turn on emergency lighting in the event of loss of normal utility power.

When Normal Power is present, the ESR relay coil is activated and the emergency panel is fed from Normal Power. The lighting load can be switched on/off using an individual wall switch.

When Normal Power drops out, the ESR coil is deactivated and N/C contact falls closed. The Automatic Transfer Switch changes over to backup (generator) power, and the lighting load is illuminated regardless of the position of the wall switch or controller scheme.

